

SSS LED Solar Sign System

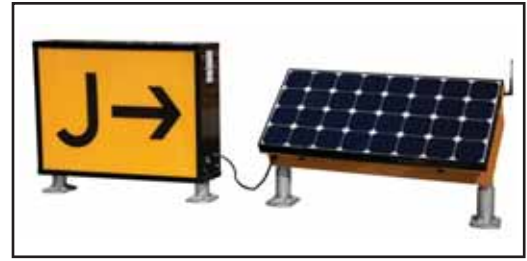

Compliance with Standards

- FAA:** Designed to meet L-858Y, L-858R L-858L and L-858B AC 150/5345-44 (Current Edition) and the FAA Engineering Brief No. 67 "Light Sources other than Incandescent and Xenon for Airport Lighting and Obstruction Lighting Fixtures."
- CE:** Complies with the requirements of the EMC Directive 2004/108/EC

Uses

ADB's LED Solar Sign System (SSS) is an ideal choice for an airfield that requires improved safety measures, but experiences difficulties with grid access. ADB's SSS consists of an L-858Y, L-858R, L-858L, L-858B solar-powered sign (SS) and a Solar Engine Power Supply (SEPS). The SEPS incorporates the latest technology in solar technology, hardware and software to provide power and control to the SS.

- **L-858Y SS:** Direction, Destination, and Boundary (Informational Sign)
- **L-858R SS:** Mandatory Sign
- **L-858L SS:** Runway/Taxiway Location Sign
These signs are designed to guide pilots to a particular point on the field, identify holding positions, identify taxiway and runway intersections, and prohibit aircraft entry into designated areas.
- **L-858B SS:** Runway Distance Remaining Sign
The L-858B SS is used at 1,000-foot intervals adjacent to the runway edge in order to provide runway distance remaining information to pilots during takeoff and landing operations.

Features

- Virtually eliminates runway shutdowns due to LED light source
- Direct replacement for existing sign
- Creates a highly uniform distribution of light, eliminating hot spots and shadows
- Operates on solar energy
- Eliminates re-lamping expenses and reduces on-going maintenance costs
- The SSS installs in minutes with no trenching, cabling, or external power, and can be relocated just as quickly.
- Battery daily depth of discharge is sized for a minimum of 5 years of service.
- Unprecedented reliability: microprocessor Energy Management System (EMS) monitors and adapts the brightness to environmental conditions for consistent operation and long life under the toughest conditions.
- The minimum autonomy or operational period without charging is 7 days.

Features (Continued)

- Protect personnel and assets: Optional hand-held wireless control allows for remote operation of a solar sign including mode changes for enhanced visibility in poor weather conditions
- Green solution: a clean, renewable and reliable energy source with the lightest environmental footprint.

Benefits

- Easy Installation: no specialized work crews required; limited air traffic disruption and functions immediately upon installation
- Compact, self-contained design; easy deployment and relocation
- Significant cost savings: no fuel or electrical bills
- Reduced maintenance cycles: no scheduled maintenance for up to five years

Sign Legends

Type	Purpose	Legend Color	Background Color
L-858Y	Direction, Destination & Boundary	Black	Yellow
L-858R	Mandatory Sign	White with Black Outline	Red
L-858L	Runway/Taxiway Location	Yellow	Black
L-858B	Runway Distance Remaining	White	Black

Operating Conditions

Temperature: -40 °F to +131 °F (-40 °C to +55 °C)

Humidity: 0 to 100%

Wind: Mode 2 signs withstand wind velocities up to 225 mph

Construction

Corrosion-resistant sign construction requires minimal maintenance.

- Aluminum housing
- Acrylic sign legend panels
- Stainless steel hardware
- Retroreflective sheeting



Installation

Each sign is furnished complete with mounting flanges for installation on a concrete pad, which is the recommended method of installation. Refer to ADB sign manual for typical sign installations. Contact ADB Sales Department for more information on sign installation hardware.

1. Floor Flange
2. 2-inch Conduit Elbow (contractor supplied)
3. L-867 Blank Cover Plate with Gasket
4. Cable from SEPS
5. L-867 Base (purchased separately)
6. L-867 Base Plate (special - purchased separately)

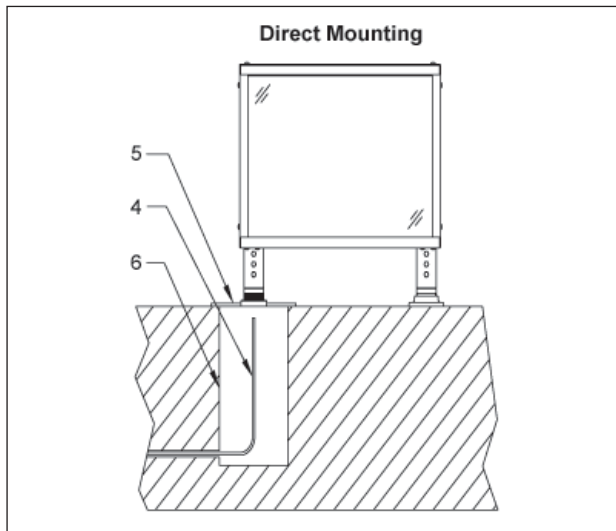
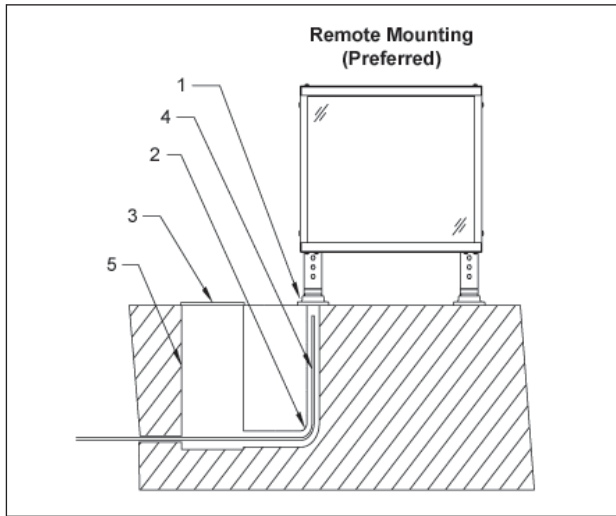

Installation (Continued)

The Solar Engine Power Supply (SEPS) has to be installed on a level concrete pad within 20 feet of the solar sign. For below ground wiring, L-867B base cans need to be installed under each SS and SEPS.

For a temporary application, the wiring between the SEPS and the SS can be above ground. Both the SS and SEPS contain side conduits for cabling access.

Solar Panel Orientation

Full solar exposure is critical to the performance of the SSS. Ensure that the SEPS installation location has year-round, unrestricted sun exposure throughout the day. The bottom edge of the solar panels should be installed at a minimum height to clear growing vegetation and snow at the site.

Note: Shading even a small portion of the solar panel will significantly reduce the output of the SSS.

Spare Components

Description	Part No.
Floor flange (2-bolt)	62A2142
Frangible coupling, size 1	60A2678-10
Frangible coupling, size 2	60A2678-20
Frangible coupling, size 3 or 5	60A2678-30
Frangible coupling, size 4	60A2678-40
Tether	94A0054
LED light engine, Size 2, 3, and 5	94A0537-20
LED light engine, Size 1 and 4	94A0537-10
LED (tube) sign power supply lead assy	44A6920
LED (tube) sign lead terminator assy	44A6921
LED (tube) sign lead jumper assy 18"	44A6922-18

Legend Panel Replacement

Ordering Code **44A6084-XXXX**

Size

- 1 = Size 1
- 2 = Size 2
- 3 = Size 3 and 5
- 4 = Size 4

Number of Modules

- 1 = 1 module
- 2 = 2 modules

Panel Type

- 1 = With legend (retroreflective)
- 2 = Blank

Sign Type

- 0 = Standard
- 1 = Hi-Wind

Equipment Data

Solar Engine Power Supply (SEPS)

Installed weight	132 lb (59.8 kg)
Shipping weight	Box 1 (SEPS) - 76 lb (34.4 kg) Box 2 (battery) - 68 lb (30.8 kg)
Installed dimensions*	29.9 H x 42.9 W x 17.4 D in (75.9 H x 108.9 W x 44.1 D cm) * with wireless antenna at 55° tilt

Shipping dimensions

Box 1 (SEPS)	25.5 H x 46.9 W x 14.0 D in (64.7 H x 119.1 W x 35.56 D cm)
Box 2 (battery)	8.3 H x 13.1 W x 7.4 D in (21 H x 33.2 W x 18.8 D cm)

Temperature

Operating:	-22 °F to +122 °F (-30 °C to +50 °C)
Storage:	-40 °F to +176 °F (-40 °C to +80 °C)

Equipment Data (Continued)

Chassis	Weather and corrosion-resistant construction of stainless steel and powder coated aluminum
Mounting	ADB frangible couplings and floor flange mounts
Wind loading	300 mph min. installed at 55° tilt
Tilt	15°, 35°, 55°
Diagnostics	On-board feedback indicators for: Battery Status, System Status, Battery Reverse Polarity, and Solar Panel Reverse Polarity
Certifications	RoHS, WEEE, CE, FCC

Battery

Power	12 VDC 105 A-hr at C/100 discharge rate
Type	Replaceable and recyclable, absorbent glass mat (AGM) SLA. Standard with one battery.
Lifetime	4,000 cycles to 20% depth of discharge at +68 °F
Charger	Temperature-compensated, maximum power point tracking (TC-MPPT)

LED Driver

Power	
Channel A:	18 – 38 VDC from 0.3 – 1.4 A and 5 – 100% duty cycle, constant current
Channel B:	18 – 38 VDC from 0.3 – 1.4 A and 5 – 100% duty cycle, constant current
Automatic Light Control (ALC)	ALC dynamically reduces brightness in response to unusually low amounts of sunlight to ensure continued autonomous operation. Available on Channels A and B.
Control, Autonomous Mode	Dusk-to-dawn, steady on
Load Cabling	22 ft. (6.7 m) cable can exit onto the surface or down into a ground pot

PV Panel

Power	17 VDC, 95 W
Type	High Efficiency Monocrystalline, IEC 61215
Lifetime	10 years at 90% output

Wireless

Range	2.5 miles minimum with 1 W wireless hand-held controller
Frequency	900 MHz ISM Band (902 – 928 MHz), FHSS
Encryption	256-bit AES
Control, On-demand Mode	<ul style="list-style-type: none"> - Seamless integration with existing ADB wireless solar products. - Up to 8 independent groups. - Flash Mode, Emergency Mode, Autonomous Mode - On-demand Temporary Mode (High, Medium, and Low) - Configuration Mode, ARCAL

Wireless Hand-Held Controller



SEPS can be controlled using the Wireless Hand-Held Controller in a similar manner to ADB's wireless solar lights.

One or more wireless solar lights can be remotely operated from the ground or air with a hand-held wireless controller using a secure radio transceiver with antenna and keypad.

The hand-held remote control option allows the user to temporarily override the intensity set in the autonomous modes. In temporary mode, 10%, 30% and 100% intensities can be selected for a 15-minute Time-Out or a Maximum Time-Out.

The 15-minute Time-Out option is for only momentary intensity brightness operations of the SSS for airports that actively manage their airfields. After 15 minutes, the SSS will be return to the autonomous configuration.

The Maximum Time-Out option is for airports that require "the most intensity for as long as possible." The SEPS software prevents the battery from being ON indefinitely at the chosen intensity, thereby preventing battery full discharge. To determine the maximum activation time for each selected intensity and region, see Table 1.

Features

- Water-resistant keypad and LED indicators
- Utilizes a secure wireless RF signal
- Control range of up to 2.5 miles
- Meets MIL-SPEC-810E environmental requirements
- 24-hour operation on a single charge
- Rechargeable lithium-ion battery (included); recharges via an AC/DC wall plug (included)
- Compatible with stand-alone aviation band VHF receiver
- Comes complete in a custom Pelican™ case

SEPS Dimensions

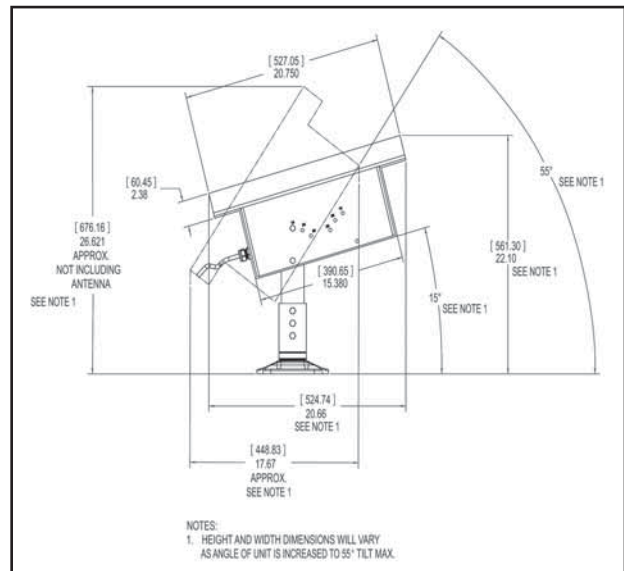

Fig. 1. SEPS Dimensions



Table 1: Maximum Activation Time for Selected Intensity and Region

SSS	Region	On-Demand Activation Time per Day, 100% Intensity (meets FAA photometrics)	On-Demand Activation Time per Day, 30% Intensity	On-Demand Activation Time per Day, 10% Intensity
Size 1,2,3,5 1 Module	1	4 hrs	12 hrs	24 hrs
	2	4 hrs	14 hrs	24 hrs
	3	6 hrs	18 hrs	24 hrs
	4	6 hrs	20 hrs	24 hrs
	5	6 hrs	22 hrs	24 hrs
Size 4 1 Module	1	2 hrs	6 hrs	18 hrs
	2	2 hrs	7 hrs	22 hrs
Size 1,2,3 2 Modules	3	3 hrs	9 hrs	24 hrs
	4	3 hrs	10 hrs	24 hrs
	5	3 hrs	11 hrs	24 hrs

Table 2: Autonomous Settings by Solar Region

SSS	Region	Autonomous Dusk-to-Dawn, % Intensity
Size 1,2,3,5 1 Module	1	22%
	2	30%
	3	36%
	4	50%
	5	64%
Size 4 1 Module	1	11%
	2	15%
Size 1,2,3 2 Modules	3	18%
	4	25%
	5	32%

Note: See Solar Map (Fig. 2) to select your region.

Sign Dimensions

Sign Heights

Type	Sign Size No.	Sign Face Height	Legend Height	Overall Mounting Height
L-858Y/R/L	1	18"	12"	29.7"
	1	(45.7 cm)	(30.5 cm)	(75.5 cm)
L-858Y/R/L	2	24"	15"	35.7"
	2	(61 cm)	(38.1)	(90.8 cm)
L-858Y/R/L	3	30"	18"	41.7"
	3	(76.2 cm)	(45.7 cm)	(106 cm)
L-858B	4	48"	40"	58.2"
	4	(122 cm)	(101.6 cm)	(147.8 cm)
L-858B	5	30"	25"	41.7"
	5	(76.2 cm)	(63.5 cm)	(106 cm)

Sign Lengths

Size No.	1 Module	2 Module
1	29.4" (75 cm)	58.6" (149 cm)
2	35.9" (91 cm)	71.6" (182 cm)
3	42.4" (108 cm)	84.6" (215 cm)
4	47.9" (122 cm)	N/A
5	42.4" (108 cm)	N/A

Note: Sign depth is 9.39 in (23.85 cm).

Solar Region Map



Fig. 2. See catalog sheet 3036 in the Solar Product Center on our website for additional solar region maps in full color. If solar region is unclear, please contact the ADB Sales Department.

Packaging Data

Signs are shipped with L-823 cord set(s), frangible couplings, and floor flanges—ready for installation.

Description	Gross Weight ¹		Carton Dimensions (in)	
	(lb)	(kg)	(in)	(cm)
Size 1, Module 1	46	21	34 x 34 x 13	87 x 86.4 x 33
Size 1, Module 2	78	35	34 x 63 x 13	87 x 160 x 33
Size 2, Module 1	71	32	40 x 40 x 13	102 x 102 x 33
Size 2, Module 2	104	47	40 x 76 x 13	102 x 193 x 33
Size 3, Module 1	81	37	46 x 46 x 13	117 x 117 x 33
Size 3, Module 2	131	60	46 x 89 x 13	117 x 226 x 33
Size 4, Module 1	120	561	62 x 52 x 13	158 x 132 x 33
Size 5, Module 1	85	39	46 x 46 x 13	117 x 117 x 33

¹ Estimated weight

SEPS Ordering Code¹ SEPS-1XXXX-XX11

Type
1 = FAA L-858 sign

Size
1 = Size 1
2 = Size 2
3 = Size 3
4 = Size 4
5 = Size 5

Modules
1 = 1 module
2 = 2 modules

Autonomous Setting²
1 = Dusk to Dawn

Solar Region³
1 = Region 1 (blue)
2 = Region 2 (green)
3 = Region 3 (white)
4 = Region 4 (yellow)
5 = Region 5 (red)

Remote Control
1 = Non-Wireless
2 = Wireless – max. time-out⁴
3 = Wireless – 15 min. time-out⁴

Note
¹ The SEPS carries the CE mark. The solar sign does not require a CE mark as it does not contain any active components.
² The SEPS is factory configured to work autonomously for dusk-to-dawn operation. On autonomous mode the product turns on at the intensity that is sustainable in that solar region. See Table 2.
³ Refer to solar map to determine solar region.
⁴ See the Wireless Hand-Held Controller section for details on Maximum Time-Out and 15-minute Time Out options.

Wireless Hand-Held Controller
Ordering Code Part # SAWL-HC

Battery Replacement Kit for
Wireless Hand-held Controller _____ Part # 48247

Solar Sign Ordering Code SXXX-SXX3XX0

Type
R = LED
S = LED High Wind¹

Sign Size
1 = Size 1
2 = Size 2
3 = Size 3
4 = Size 4
5 = Size 5

Module
1 = 1 Module
2 = 2 Modules

Style
S = Solar

Face
1 = Single
2 = Double

Total Number of Panels
2 = 2 panel sign
3 = 3 panel sign
4 = 4 panel sign
3

Power
8 = Solar - power through leg/power through side with ON/OFF switch²

Tether
0 = No tether
1 = One tether on one end of sign

Notes
¹ Use high wind signs in locations where actual wind speed exceeds FAA specifications (Mode 3). High wind signs are tested to a minimum wind load of 327 mph as recommended by FAA technical paper DOT/FAA/AR-TN00/32: Evaluation of Wind-Loading on Airport Signs. High wind signs require four anchor bolts per floor flange except Size 1, which uses the standard 2-bolt foot.
² Customer to provide legend information and power connection location. It is important to match power cord exit location with legend side.

Canada Brasil
canada@adb-air.com brasil@adb-air.com
+1.905.331.6887 +55 (11) 6615.7209

ADB Airfield Solutions
Leuvensesteenweg 585
B-1930 Zaventem
Belgium

Telephone: +32 (2) 722.17.11
Fax: +32 (2) 722.17.64
www.adb-airfieldsolutions.com

Product specifications may be subject to change, and specifications listed here are not binding. Confirm current specifications at time of order.

ADB Airfield Solutions, LLC
977 Gahanna Parkway
Columbus, OH 43230
USA

Telephone: +1 614.861.1304
+1 800.545.4157
Fax: +1 614.864.2069
www.adb-airfield.com