

## SWCS LED Solar Wind Cone System



### Compliance with Standards

- FAA:** Designed to meet L-806 and L-807 AC 150/5345-27 (Current Edition).
- CE:** Complies with the requirements of the EMC Directive 2004/108/EC

### Uses

ADB's LED Solar Wind Cone System (SWCS) is an ideal choice for an airfield that requires improved safety measures, but experiences difficulties with grid access. ADB's SWCS consists of either an L-806 or L-807 solar-powered wind cone (SWC) and a Solar Engine Power Supply (SEPS). The SWC provides visual surface wind direction and velocity information to pilots in flight or on the ground at airports and heliports. The SEPS incorporates the latest in solar technology, hardware and software to provide power and control to the SWC.

### Features

- The L-806 SWC is a low-mass, frangible-designed wind cone available in two lighted styles, internal or external, with an eight-foot wind sock
- The L-807 SWC is a non-frangible designed wind cone available in two lighted styles, internal or external, and in two sizes, eight- or twelve-foot wind socks
- The SWCS installs in minutes with no trenching, cabling, or external power, and can be relocated just as quickly.
- L-807 12-foot pole is available with either a center hinge or bottom hinge. Center hinge allows easier pole lowering. Bottom hinge includes a swing-out support leg that allows the mast to be lowered to a convenient servicing height for light source replacement.
- Sealed bearings allow precision vaning for true wind direction in all types of weather and wind conditions
- Bearing covers are provided for additional bearing protection against dirt and moisture
- The nylon fabric sock is treated for water repellency and resistance to rot and mildew
- The standard color is orange and the colorfastness exceeds Method 5671 of Federal Standard 191. Other colors such as alternate orange/white banded are available as a special order.
- Battery daily depth of discharge is sized for a minimum of 5 years of service.
- Unprecedented reliability: microprocessor Energy Management System (EMS) monitors and adapts the brightness to environmental conditions for consistent operation and long life under the toughest conditions.
- The minimum autonomy or operational period without charging is 7 days.

### Features (Continued)

- Protect personnel and assets: Optional hand-held wireless control allows for remote operation of an SWC including mode changes for enhanced visibility in poor weather conditions
- Green solution: a clean, renewable and reliable energy source with the lightest environmental footprint.

### Lighting Assembly - LED

- The internally lighted wind cone can provide an average illumination on the top and lateral surface of a fully extended windsock of 10- to 30-ft lamberts. The internally lighted 8-foot wind cone uses one LED optical assembly and the 12-foot uses three LED optical assemblies.
- The externally lighted wind cone can provide a minimum illumination of 2 foot candles on the upper surface of the fully extended windsock. The externally lighted 8- and 12-foot wind cones use two LED optical assemblies.



Externally Lit LED  
Wind Cone



Internally Lit 12-Foot  
LED Wind Cone

### Operating Conditions

Temperature: -40 °F to +131 °F (-40 °C to +55 °C)

Humidity: 0 to 100%

Wind: Withstands wind velocities up to 300 mph (480 kph)

### Benefits

- Easy Installation: no specialized work crews required; limited air traffic disruption and functions immediately upon installation
- Compact, self-contained design; easy deployment and relocation
- Significant cost savings: no fuel or electrical bills
- Reduced maintenance cycles: no scheduled maintenance for up to five years

## Wireless Hand-Held Controller



SEPS can be controlled using the Wireless Hand-Held Controller in a similar manner to ADB's wireless solar lights.

One or more wireless solar lights can be remotely operated from the ground or air with a hand-held wireless controller using a secure radio transceiver with antenna and keypad.

The hand-held remote control option allows the user to temporarily override the intensity set in the autonomous modes. In temporary mode, 10%, 30% and 100% intensities can be selected for a 15-minute Time-Out or a Maximum Time-Out.

The 15-minute Time-Out option is for only momentary intensity brightness operations of the SWCS for airports that actively manage their airfields. After 15 minutes, the SWCS will return to the autonomous configuration.

The Maximum Time-Out option is for airports that require "the most intensity for as long as possible." The SEPS software prevents the battery from being ON indefinitely at the chosen intensity, thereby preventing battery full discharge. To determine the maximum activation time for each selected intensity and region, see Table 1.

### Features

- Water-resistant keypad and LED indicators
- Utilizes a secure wireless RF signal
- Control range of up to 2.5 miles
- Meets MIL-SPEC-810E environmental requirements
- 24-hour operation on a single charge
- Rechargeable lithium-ion battery (included); recharges via an AC/DC wall plug (included)
- Compatible with stand-alone aviation band VHF receiver
- Comes complete in a custom Pelican™ case

### Equipment Data

#### Solar Engine Power Supply (SEPS)

Installed weight	132 lb (59.8 kg)
Shipping weight	Box 1 (SEPS) - 76 lb (34.4 kg) Box 2 (battery) - 68 lb (30.8 kg)
Installed dimensions*	29.9 H x 42.9 W x 17.4 D in (75.9 H x 108.9 W x 44.1 D cm) * with wireless antenna at 55° tilt
Shipping dimensions	
Box 1 (SEPS)	25.5 H x 46.9 W x 14.0 D in (64.7 H x 119.1 W x 35.56 D cm)
Box 2 (battery)	8.3 H x 13.1 W x 7.4 D in (21 H x 33.2 W x 18.8 D cm)
Temperature	
Operating:	-22 °F to +122 °F (-30 °C to +50 °C)
Storage:	-40 °F to +176 °F (-40 °C to +80 °C)
Chassis	Weather and corrosion-resistant construction of stainless steel and powder coated aluminum

### Equipment Data (Continued)

Mounting	ADB frangible couplings and floor flange mounts
Wind loading	300 mph min. installed at 55° tilt
Tilt	15°, 35°, 55°
Diagnostics	On-board feedback indicators for: Battery Status, System Status, Battery Reverse Polarity, and Solar Panel Reverse Polarity
Certifications	RoHS, WEEE, CE, FCC
<b>Battery</b>	
Power	12 VDC 105 A-hr at C/100 discharge rate
Type	Replaceable and recyclable, absorbent glass mat (AGM) SLA. Standard with one battery.
Lifetime	4,000 cycles to 20% depth of discharge at +68 °F
Charger	Temperature-compensated, maximum power point tracking (TC-MPPT)

### LED Driver

Power	18 – 38 VDC from 0.3 – 1.4 A and 5 – 100 % duty cycle, constant current
Automatic Light Control (ALC)	ALC dynamically reduces brightness in response to unusually low amounts of sunlight to ensure continued autonomous operation.
Control, Autonomous Mode	Dusk-to-dawn, steady on
Load Cabling	22 ft (6.7 m) cable can exit onto the surface or down into a ground pot

### PV Panel

Power	17 VDC, 95 W
Type	High Efficiency Monocrystalline, IEC 61215
Lifetime	10 years at 90% output

### Wireless

Range	2.5 miles minimum with 1W wireless hand-held controller
Frequency	900 MHz ISM Band (902 – 928 MHz), FHSS
Encryption	256-bit AES
Control, On-demand Mode	- Seamless integration with existing ADB wireless solar products. - Up to 8 independent groups. - Flash Mode, Emergency Mode, Autonomous Mode - On-demand Temporary Mode (High, Medium, and Low) - Configuration Mode, ARCAL

### Solar Panel Orientation

Full solar exposure is critical to the performance of the SWCS. Ensure that the SEPS installation location has year-round, unrestricted sun exposure throughout the day. The bottom edge of the solar panels should be installed at a minimum height to clear growing vegetation and snow at the site.

**Note:** Shading even a small portion of the solar panel will significantly reduce the output of the SWCS.

**Table 1: Maximum Activation Time for Selected Intensity and Region**

SWC	Region	On-Demand Activation Time per Day, 100% Intensity (meets FAA photometrics)	On-Demand Activation Time per Day, 30% Intensity	On-Demand Activation Time per Day, 10% Intensity
8ft WC Internally Lit, 1 LED Module	1	6 hrs	20 hrs	24 hrs
	2	8 hrs	24 hrs	24 hrs
	3	8 hrs	24 hrs	24 hrs
	4	10 hrs	24 hrs	24 hrs
	5	12 hrs	24 hrs	24 hrs
12ft WC Internally Lit, 3 LED Modules	1	1 hrs	5 hrs	12 hrs
	2	2 hrs	6 hrs	12 hrs
	3	2 hrs	7 hrs	12 hrs
	4	2 hrs	8 hrs	12 hrs
	5	3 hrs	9 hrs	12 hrs
WC Externally Lit, 2 LED Modules	1	3 hrs	10 hrs	24 hrs
	2	4 hrs	12 hrs	24 hrs
	3	4 hrs	15 hrs	24 hrs
	4	5 hrs	17 hrs	24 hrs
	5	6 hrs	19 hrs	24 hrs

**Table 2: Autonomous Settings by Solar Region**

SWC	Region	Autonomous Dusk-to-Dawn, % Intensity
Internally Lit, 1 LED Module	1	38%
	2	50%
	3	62%
	4	86%
	5	100%
Internally Lit, 3 LED Modules	1	10%
	2	13%
	3	16%
	4	22%
	5	27%
Externally Lit, 2 LED Modules	1	19%
	2	25%
	3	31%
	4	43%
	5	53%

**Note:** See Solar Map (Fig. 2) to select your region.

**Dimensions**

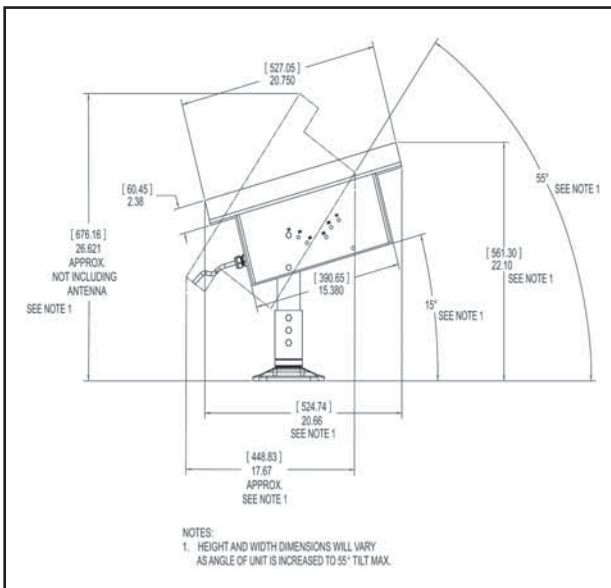

**Fig. 1. SEPS Dimensions**

**Solar Region Map**

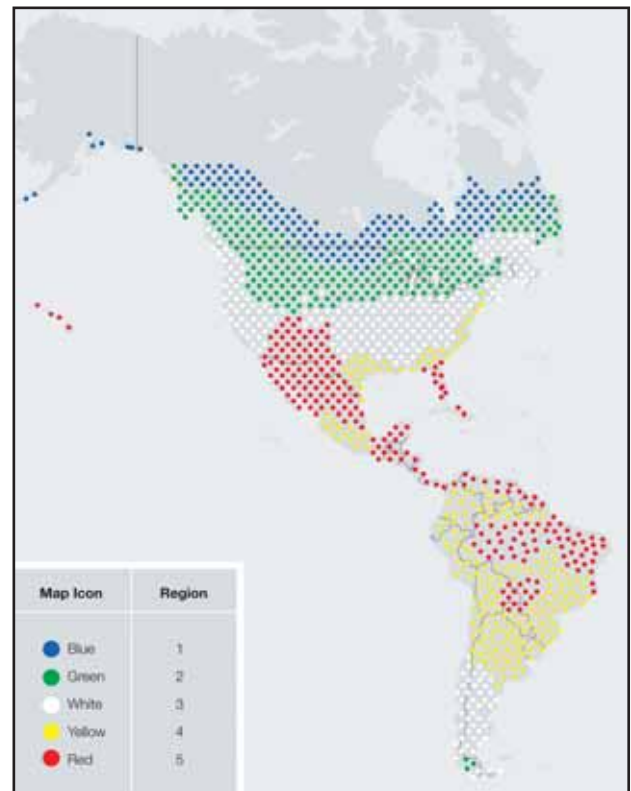

**Fig. 2.** See catalog sheet 3036 in the Solar Product Center on our website for additional solar region maps in full color. If solar region is unclear, please contact the ADB Sales Department.



**L-806 and L-807 SWC Internally and Externally Lighted Assemblies**

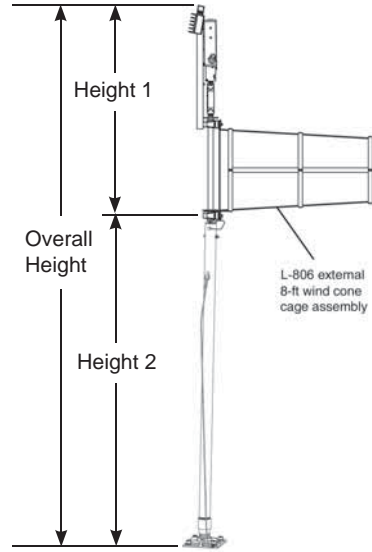
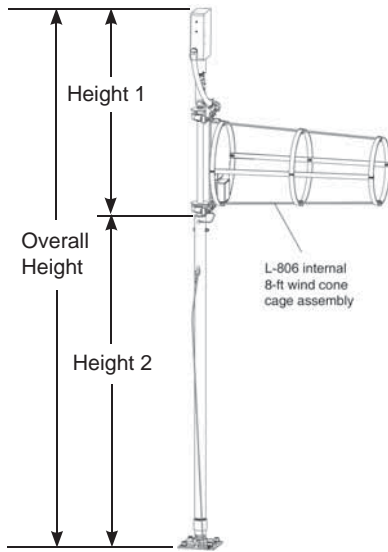

**Dimensions - Internally Lighted**

Wind Cone Type	Overall Height	Height 1	Height 2
L-806 LED Internal	116.3 in (295.4 cm)	44.3 in (112.5 cm)	72 in (182.9 cm)
L-807 LED 8 ft Internal	233.9 in (622.8 cm)	41.9 in (135.1 cm)	192 in (487.7 cm)
L-807 LED 12 ft Internal	252.1 in (669.0 cm)	60.1 in (181.4 cm)	192 in (487.7 cm)

**Dimensions - Externally Lighted**

Wind Cone Type	Overall Height	Height 1	Height 2
L-806 LED External	119.6 in (303.8 cm)	47.6 in (120.9 cm)	72 in (182.9 cm)
L-807 8 ft External	237.2 in (622.8 cm)	45.2 in (28.5 cm)	192 in (60.7 cm)
L-807 12 ft External	263 in (679.5 cm)	71 in (61.2 cm)	192 in (127 cm)

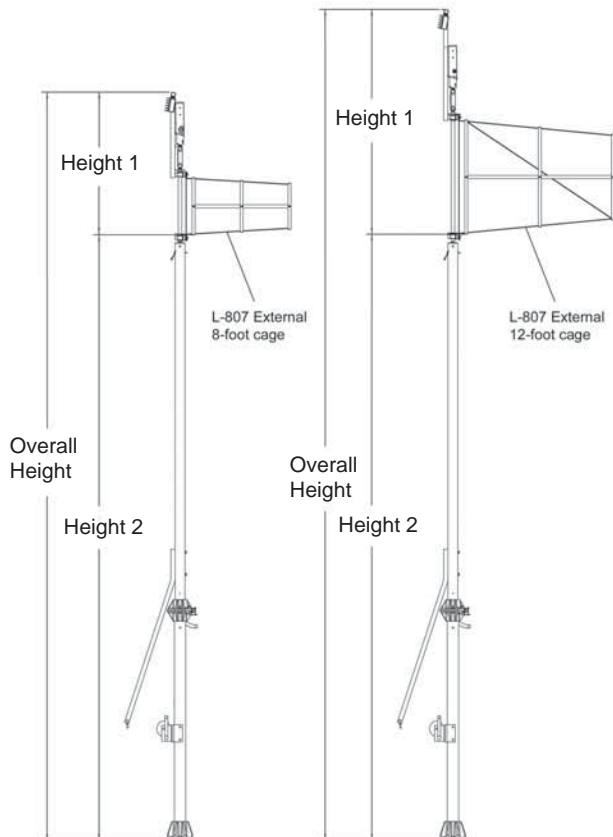
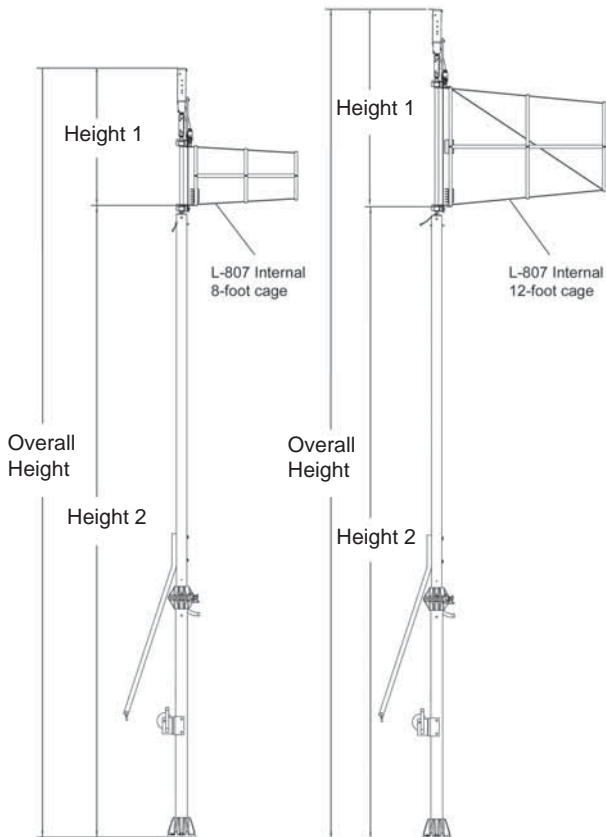

**LED Internally Lighted Wind Cone Assembly**

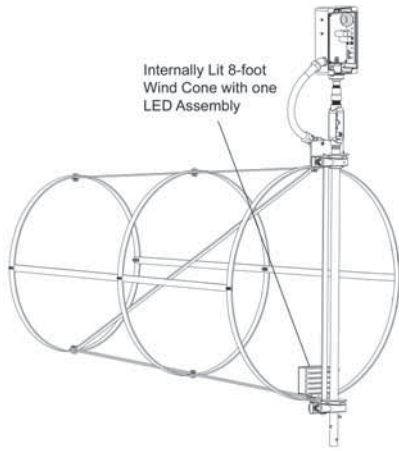

8-foot internally lit wind cone has one LED assembly

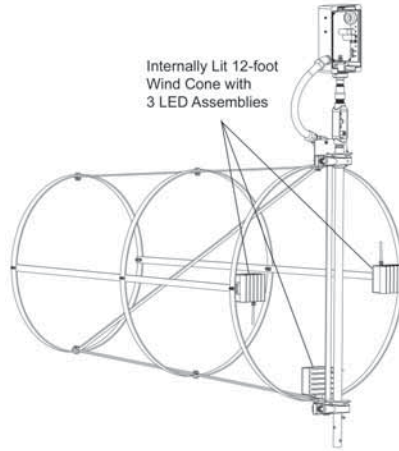

12-foot internally lit wind cone has three LED assemblies

**LED Externally Lighted Wind Cone Assembly**

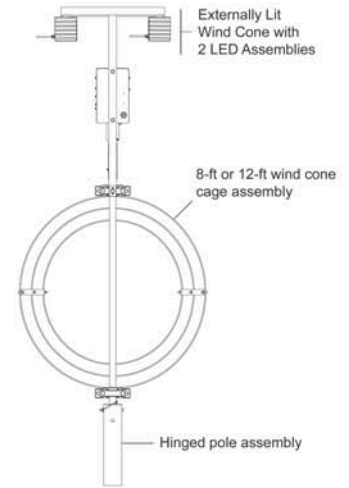

8- and 12-foot externally lit wind cones have two LED assemblies

**Center-hinged Pole**

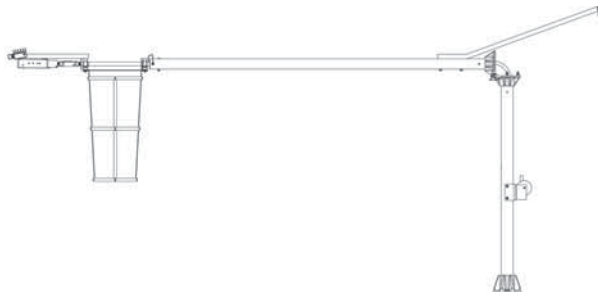

**Packaging**

Description	Quantity Per Box	Dimensions (H x W x D)	Weight
8-ft. Wind Cone Lighted	1 Pole	16.6 x 10 x 10 in 502.9 x 25.4 x 25.4 cm	150 lb 68 kg
	1 Basket	20 x 20 x 15 in 50.8 x 50.8 x 38.1 cm	47 lb 21.3 kg
8-ft. Wind Cone Unlighted	1 Pole	16.6 x 10 x 10 in 502.9 x 25.4 x 25.4 cm	135 lb 61.2 kg
	1 Basket	20 x 20 x 15 in 50.8 x 50.8 x 38.1 cm	42 lb 19.1 kg
12-ft. Wind Cone Lighted	1 Pole	16.6 x 10 x 10 in 502.9 x 25.4 x 25.4 cm	150 lb 68 kg
	1 Basket	45 x 42 x 6 in 114.3 x 106.7 x 15.2 cm	47 lb 21.3 kg
	Hardware	20 x 20 x 15 in 50.8 x 50.8 x 38.1 cm	45 lb 20.4 kg
12-ft. Wind Cone Unlighted	1 Pole	16.6 x 10 x 10 in 502.9 x 25.4 x 25.4 cm	135 lb 61.2 kg
	1 Basket	45 x 42 x 6 in 114.3 x 106.7 x 15.2 cm	42 lb 19.1kg
	Hardware	20 x 20 x 15 in 50.8 x 50.8 x 38.1 cm	45 lb 20.4 kg

**Operation**

The operation of the wind cone is entirely dependent on the direction and relative velocity of the surface wind. Movement of the wind through the open throat of the cage and into the sock causes the tail to inflate. The tail of the inflated sock indicates true wind direction for velocities as low as three knots through a 360° circle about the vertical shaft.

**Spare Components (LED)**

Description	Part No.
Windsock 8ft	77C0061-1
Windsock 12ft	77C0062-1
LED Module	44A6786

**Installation**

The SWC should be installed according to FAA AC 150/5340-30.

The Solar Engine Power Supply (SEPS) has to be installed on a level concrete pad within 20 feet of the SWC. For below ground wiring, L-867B base cans need to be installed under each SEPS.

For a temporary application, the wiring between the SEPS and the SWC can be above ground. Both the SWC and SEPS contain side conduits for cabling access.

**FAA Wind Cone Classifications**

Size 1:	8 foot
Size 2:	12 foot
Style I-A:	Externally Lighted
Style I-B:	Internally Lighted



**SEPS Ordering Code<sup>1</sup>**      **SEPS-2XXXX-XX11**

**Type**  
 1 = L-806 SWC, 8 foot  
 2 = L-807 SWC, 8 foot  
 3 = L-807 SWC, 12-foot

**Lighting**  
 1 = Internal  
 2 = External

**Obstruction Light**  
 1 = No obstruction light

**Autonomous Setting<sup>2</sup>**  
 1 = Dusk to Dawn

**Solar Region<sup>3</sup>**  
 1 = Region 1 (blue)  
 2 = Region 2 (green)  
 3 = Region 3 (white)  
 4 = Region 4 (yellow)  
 5 = Region 5 (red)

**Remote Control**  
 1 = Non-Wireless  
 2 = Wireless – max. time-out<sup>4</sup>  
 3 = Wireless – 15 min. time-out<sup>4</sup>

**Note**  
<sup>1</sup> The SEPS carries the CE mark. The SWC does not require a CE mark as it does not contain any active components.  
<sup>2</sup> The SEPS is factory configured to work autonomously for dusk-to-dawn operation. On autonomous mode the product turns on at the intensity that is sustainable in that solar region. See Table 2.  
<sup>3</sup> Refer to solar map to determine solar region.  
<sup>4</sup> See the Wireless Hand-Held Controller section for details on Maximum Time-Out and 15-minute Time Out options.

**Wireless Hand-Held Controller**  
**Ordering Code**      **Part # SAWL-HC**

Battery Replacement Kit for  
 Wireless Hand-held Controller      Part # 48247

**L-806 SWC Ordering Code<sup>1</sup>**      **WC806-1XXX**

**Size**  
 1 = 8-foot cage

**Style**  
 9 = Internally lit LED solar<sup>2</sup>  
 A = Externally lit LED solar

**Obstruction Light**  
 0 = No obstruction light  
 A = Obstruction light, red SATO<sup>4</sup>

**Special Applications**  
 0 = No components removed (standard)  
 1 = No wind sock<sup>3</sup>

**Notes**  
<sup>1</sup> L-806 SWC should only be powered with a SEPS  
<sup>2</sup> Internally lighted 8-foot L-806 is a non-FAA configuration.  
<sup>3</sup> For applications where wind socks other than orange are used. Special wind sock colors supplied separately.  
<sup>4</sup> See ADB catalog sheet 3014 for more details.

**L-807 SWC Ordering Code<sup>1</sup>**      **WC807-XXXXX**

**Size**  
 1 = 8-foot cage<sup>1</sup>  
 2 = 12-foot cage

**Hinge**  
 1 = Bottom-hinged pole  
 2 = Center-hinged pole

**Style**  
 9 = Internally lit LED solar<sup>2</sup>  
 A = Externally lit LED solar

**Obstruction Light**  
 0 = No obstruction light  
 A = Obstruction light, red SATO<sup>4</sup>

**Special Applications**  
 0 = No components removed (standard)  
 1 = No wind sock<sup>3</sup>

**Notes**  
<sup>1</sup> L-807 SWC should only be powered with a SEPS  
<sup>2</sup> Internally lighted 8-foot L-806 is a non-FAA configuration.  
<sup>3</sup> For applications where wind socks other than orange are used. Special wind sock colors supplied separately.  
<sup>4</sup> See ADB catalog sheet 3014 for more details.

ADB Airfield Solutions  
 Leuvensesteenweg 585  
 B-1930 Zaventem  
 Belgium

Telephone: +32 (2) 722.17.11  
 Fax: +32 (2) 722.17.64  
 www.adb-airfieldsolutions.com

Canada  
 canada@adb-air.com  
 +1.905.331.6887

Brasil  
 brasil@adb-air.com  
 +55 (11) 6615.7209

ADB Airfield Solutions, LLC  
 977 Gahanna Parkway  
 Columbus, OH 43230  
 USA

Telephone: +1 614.861.1304  
 +1 800.545.4157  
 Fax: +1 614.864.2069  
 www.adb-airfield.com

*Product specifications may be subject to change, and specifications listed here are not binding. Confirm current specifications at time of order.*

3029 Rev. E  
 Manual No. 96A0425